



Glass and Solid Door Models Available



HYC-1031GDH/FDH



±1.5°C

Temperature Uniformity of ±1.5°C



35% -75%

Cabin's Real Time Humidity is Maintained at 35% -75%



3.2 kWh

Low Energy Consumption of 3.2kWh/day



39 dB(A)

Quiet Operation with 39dB

Pharmacy Refrigerator

Scope of Application

Used for storage of medicines, vaccines, reagents, biological products and other items that require a temperature between 2-8°C and humidity stability in hospitals, pharmacies, pharmaceutical factories, clinics and laboratories etc.

Innovative Design

- Real transient humidity control
- Ergonomic design with high performance, low energy consumption and low noise level
- Condensation free even at ambient 32°C & 80% RH
- Multi types intelligent control to achieve humidity stability
- Self-closing door hinge

Qingdao Haier Biomedical Co., Ltd.

No.280 Feng Yuan Road, High-tech Zone,
Qingdao, 266111, P.R. China
E-mail: inquiry@haierbiomedical.com
Website: www.haiermedical.com



Mar, 2026



Haier Biomedical



Haier Biomedical International



Haier Biomedical International



Haier Biomedical International



Haier Biomedical International

Product Features



Whole space circulation, multi-dimension intelligent control and smart dehumidification technology to maintain real-time humidity inside the cabin at 35% -75%, providing suitable humidity for medicine storage.



Microprocessor controller, smart inverter compressor, optimized air-cooling technology with auto defrost to ensure excellent cooling performance, defrost water to evaporate automatically.



HYC-1031GDH: Triple-paned tempered glass door with frame heater to achieve condensation free even at 32°C, 80% RH ambient; self-closing door; magnetic gaskets to ensure a positive seal.

HYC-1031FDH: Triple-paned tempered solid door with frame heater to achieve condensation free even at 32°C, 80% RH ambient; self-closing door; magnetic gaskets to ensure a positive seal.



Multiple alarm functions for safer monitoring, audible/visual alert with mute function; remote alarm contact is equipped as standard.



Energy efficient interior LED lighting, side-mounted to light up whole space.



Two 25mm probe access ports on each side wall to accept user-provided monitoring equipment.



Optional USB module to easily record and export cabinet temperature and alarm data; Optional RS485 port and remote alarm contact for easily external connection; Optional printer to easily export cabinet temp data.



Adjustable plastic-coated wire shelves for improved circulation and flexible storage, 4 swivel casters with 2 leveling feet for easy movement and fixing.



Product Dimension

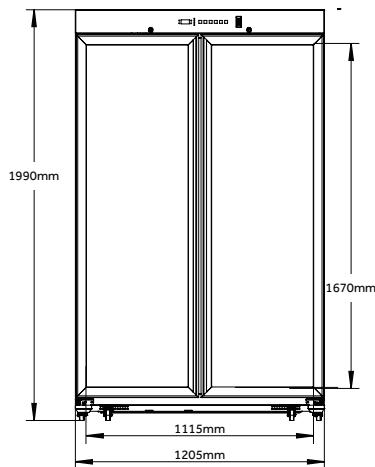

Front view

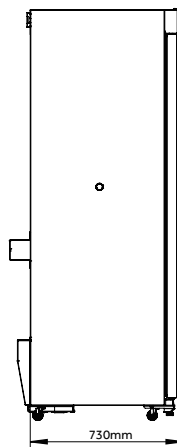

Side view

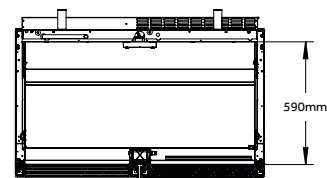

Top view

Specifications



Model		HYC-1031GDH	HYC-1031FDH	
Technical Data	Cabinet Type	Upright, Glass Door	Upright, Solid Door	
	Climate Class	N, 16-32°C	N, 16-32°C	
	Cooling Type	Forced Air Cooling	Forced Air Cooling	
	Defrost Mode	Auto	Auto	
	Refrigerant	R290, 80g	R290, 80g	
	Sound Level (dB(A))	39	/	
Performance	Temperature Range (°C)	2-8°C	2-8°C	
	Humidity Range	35%-75%	35%-75%	
Control	Controller	Microprocessor	Microprocessor	
	Display	Digital Display with Resolution of 0.1°C	Digital Display with Resolution of 0.1°C	
Electrical Data	Power Supply (V/Hz)	220-240/50/60	220-240/50/60	
	Power (W)	450	410	
	Power Consumption (kWh/day)	3.2	1.6	
Dimensions	Capacity (L/Cu.Ft)	1031/36.4	1031/36.4	
	Net/Gross Weight (approx)	kg	255/265	235/245
		lbs	562/584	562/584
	Interior Dimensions (W*D*H)	mm	1115*590*1670	1115*590*1670
		in	43.9*23.2*65.7	43.9*23.2*65.7
	Exterior Dimensions (W*D*H)	mm	1205*800*1990	1205*800*1990
		in	47.4*28.7*78.3	47.4*28.7*78.3
	Packing Dimensions (W*D*H)	mm	1310*925*2150	1310*925*2150
in		51.6*36.4*84.6	51.6*36.4*84.6	
Container Load (20'/40'/40'H)		10/21/21	10/21/21	
Alarms	High/Low Temperature	Y	Y	
	High Ambient Temperature	Y	Y	
	Door Ajar	Y	Y	
	Power Failure	Y	Y	
	Low Battery	Y	Y	
	Sensor Error	Y	Y	
	Communication Failure	Y	Y	
	Condenser Heat	Y	Y	
	Remote Alarm	Y	Y	
	Caster	4	4	
Accessories	Leveling Foot	2	2	
	Access Port	2	2	
	Shelves	12 Adjustable + 2 Bottom Located	12 Adjustable + 2 Bottom Located	
	Plastic Basket	Yes, 2 Optional	Yes, 2 Optional	
	Printer	Optional	Optional	
	Chart Recorder	N/A	N/A	
	USB Interface	Optional	Optional	
RS485	Optional	Optional		
Others	Certification	CE	CE	

*Haier Biomedical reserves the right to change products and specifications without prior notice.